

2A Surface Mount Glass Passivated Bridge Rectifier

Features

- Glass Passivated Chip Junction
- Reverse Voltage - 100 to 1000 V
- Forward Current - 2 A
- High Surge Current Capability
- Designed for Surface Mount Application

PIN	DESCRIPTION
1	Input Pin (~)
2	Input Pin (~)
3	Output Anode (+)
4	Output Cathode (-)

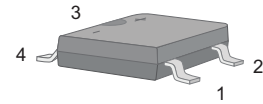

ABS/LBF Package

Mechanical Data

- Case: ABS/LBF(AS/LF)
- Terminals: Solderable per MIL-STD-750, Method 2026
- Approx. Weight: 88mg 0.0031oz

Maximum Ratings and Characteristics

Ratings at 25 °C ambient temperature unless otherwise specified.

Single phase half-wave 60 Hz, resistive or inductive load, for capacitive load current derate by 20 %.

Parameter	Symbols	LTA1S-20	LTA2S-20	LTA4S-20	LTA6S-20	LTA8S-20	LTA10S-20	Units
Maximum Repetitive Peak Reverse Voltage	V_{RRM}	100	200	400	600	800	1000	V
Maximum RMS voltage	V_{RMS}	70	140	280	420	560	700	V
Maximum DC Blocking Voltage	V_{DC}	100	200	400	600	800	1000	V
Average Rectified Output Current at $T_c = 115\text{ }^\circ\text{C}$	I_o	2.0						A
Peak Forward Surge Current 8.3 ms Single Half Sine Wave Superimposed on Rated Load (JEDEC Method)	I_{FSM}	50						A
Forward Voltage per element @ $I_F = 2.0\text{A}$	V_F	1.0						V
Maximum DC Reverse Current @ $T_A = 25\text{ }^\circ\text{C}$ at Rated DC Blocking Voltage @ $T_A = 125\text{ }^\circ\text{C}$	I_R	5.0 100						μA
Typical Junction Capacitance (Note1)	C_j	25						pF
Typical Thermal Resistance (Note2)	$R_{\theta JA}$ $R_{\theta JC}$	60 16						$^\circ\text{C/W}$
Operating and Storage Temperature Range	T_j, T_{stg}	-55 ~ +150						$^\circ\text{C}$

Note: 1. Measured at 1MHz and applied reverse voltage of 4 V D.C.

2. Mounted on glass epoxy PC board with 4×1.5"×1.5" (3.81×3.81 cm) copper pad.

Ratings and Characteristics Curves

Fig.1 Average Rectified Output Current Derating Curve

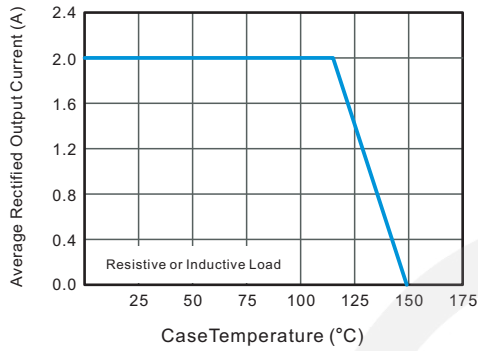

Fig.2 Typical Reverse Characteristics

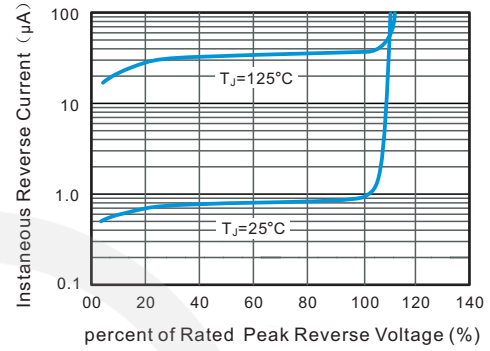

Fig.3 Typical Instantaneous Forward Characteristics

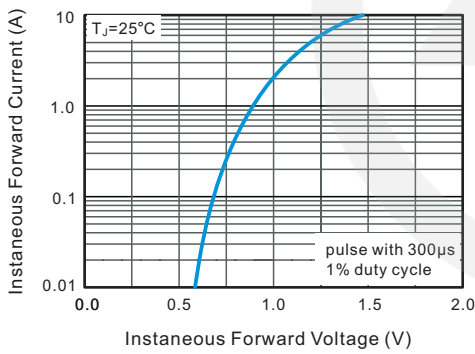

Fig.4 Typical Junction Capacitance

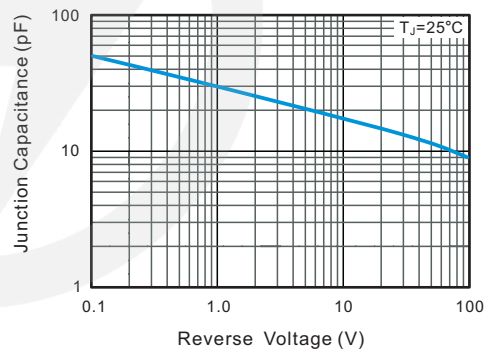
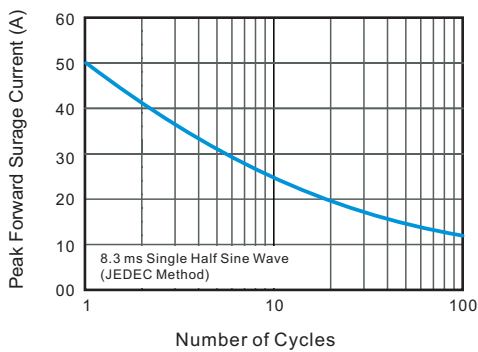
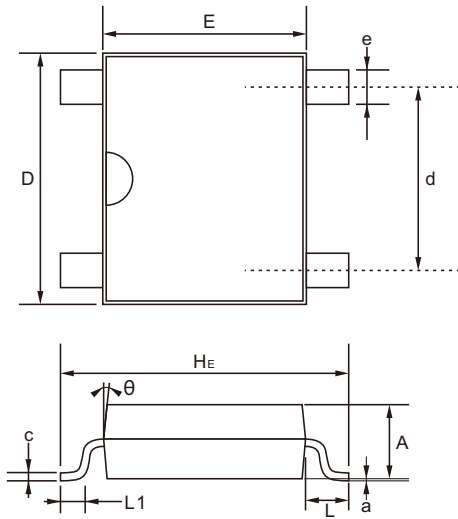

Fig.5 Maximum Non-Repetitive Peak Forward Surge Current



ABS/LBF Package Outline



Unit: mm

SYMBOL	DIMENSIONS	
	MIN.	MAX.
A	1.300	1.500
C	0.150	0.220
D	4.900	5.200
E	4.200	4.500
He	6.000	6.400
d	3.800	4.200
e	0.500	0.700
L	0.950 TYP.	
L1	0.600 TYP.	
a	0.200 TYP.	
θ	7°	

ABS/LBF Suggested Pad Layout

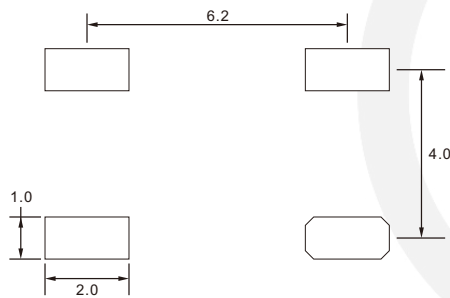

Note:

1. Controlling dimension: in millimeters.
2. General tolerance: $\pm 0.05\text{mm}$
3. The pad layout is for reference purpose only.

Marking

Type number	Marking code
LTA1S-20	ABS201
LTA2S-20	ABS202
LTA4S-20	ABS204
LTA6S-20	ABS206
LTA8S-20	ABS208
LTA10S-20	ABS210

Recommended Soldering Conditions

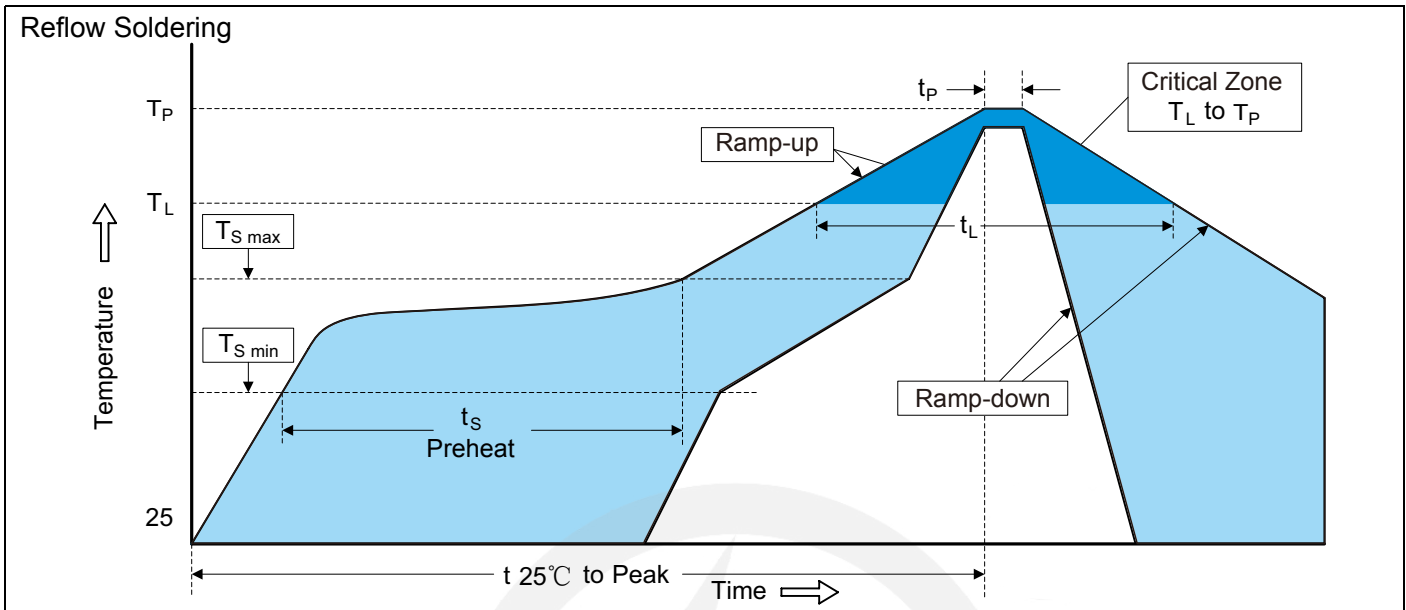

Recommended Conditions

Profile Feature	Pb-Free Assembly
Average ramp-up rate (T_L to T_P)	3°C/second max.
Preheat -Temperature Min ($T_{S\ min}$) -Temperature Max ($T_{S\ max}$) -Time (min to max) (t_s)	150°C 200°C 60-180 seconds
$T_{S\ max}$ to T_L -Ramp-up Rate	3°C/second max.
Time maintained above: -Temperature (T_L) -Time (t_L)	217°C 60-150 seconds
Peak Temperature (T_P)	260°C
Time within 5°C of actual Peak Temperature (t_P)	20-40 seconds
Ramp-down Rate	6°C/second max.
Time 25°C to Peak Temperature	8 minutes max.

Packaging

13" Reel

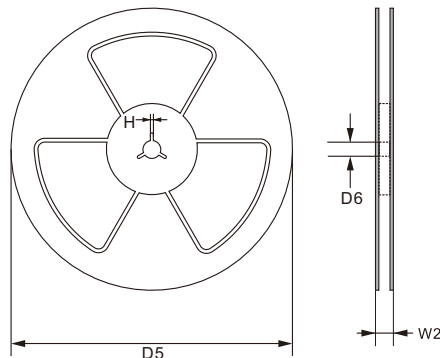

D5 $\Phi 330.0 \pm 2.0$

D6 $\Phi 13.5 \pm 0.5$

H 2.5 ± 1.0

W2 16.0 ± 2.0

Quantity: 5000PCS